

<Full-SiC Modules>

FMF400BX-24A

HIGH POWER SWITCHING USE
INSULATED TYPE

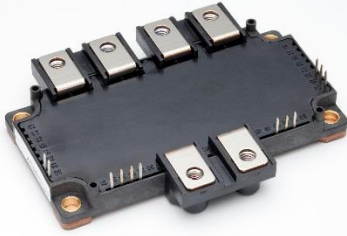

4in1

Drain current I_D 400 A
 Drain-Source voltage V_{DSX} 1200 V
 Maximum junction temperature T_{vjmax} 150 °C

- Silicon Carbide MOSFET + Silicon Carbide Schottky Barrier Diode
- Flat base Type
- Copper base plate
- RoHS Directive compliant
- Recognized under UL1557, File E323585

APPLICATION

AC Motor Control, Motion/Servo Control, Power supply, etc.

OUTLINE DRAWING & INTERNAL CONNECTION

Dimension in mm

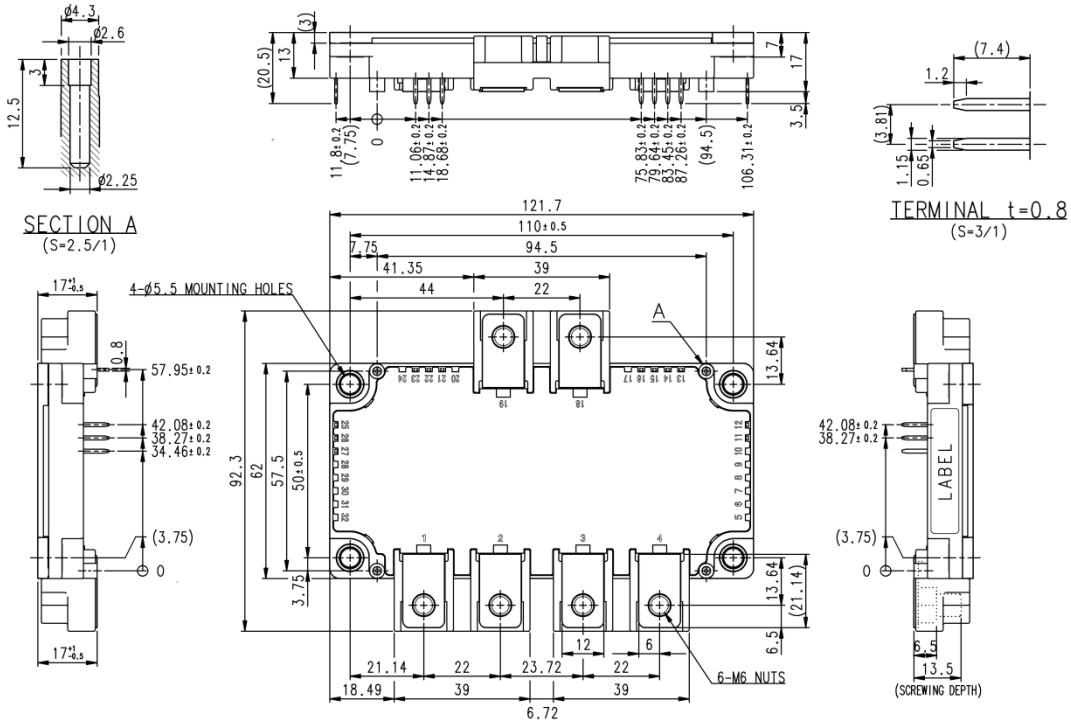

INTERNAL CONNECTION

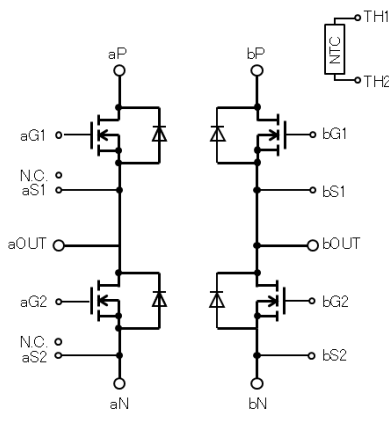

Terminal code

- 1 aP
- 2 aN
- 3 bN
- 4 bP
- 11 bG1
- 12 bS1
- 13 TH2
- 14 TH1
- 15 bG2
- 16 bS2
- 18 bOUT
- 19 aOUT
- 21 aS2
- 22 N.C.
- 23 aG2
- 25 aS1
- 26 N.C.
- 27 aG1

Tolerance otherwise specified

Division of Dimension	Tolerance
0.5 to 3	±0.2
over 3 to 6	±0.3
over 6 to 30	±0.5
over 30 to 120	±0.8
over 120 to 400	±1.2

FMF400BX-24AHIGH POWER SWITCHING USE
INSULATED TYPEMAXIMUM RATINGS ($T_{vj}=25\text{ }^{\circ}\text{C}$, unless otherwise specified)

Symbol	Item	Conditions	Rating	Unit
V_{DSX}	Drain-source voltage	$V_{GS}=-15\text{ V}$	1200	V
V_{GSS}	Gate-source voltage	D-S short-circuited	± 20	V
I_D	Drain current	DC	400	A
I_{DRM}		Pulse, Repetitive, $T_{vj}=150\text{ }^{\circ}\text{C}$ (Note.3)	800	
P_{tot}	Total power dissipation	$T_C=25\text{ }^{\circ}\text{C}$ (Note.2, 4)	1485	W
I_S (Note.1)	Source current	DC	400	A
I_{SRM} (Note.1)		Pulse, Repetitive, $T_{vj}=150\text{ }^{\circ}\text{C}$ (Note.3)	800	
V_{isol}	Isolation voltage	Terminals to base plate, RMS, $f=60\text{ Hz}$, AC 1 min	4000	V
T_{vjmax}	Maximum junction temperature	Instantaneous event (overload)	150	$^{\circ}\text{C}$
T_{Cmax}	Maximum case temperature	(Note.2)	125	
T_{vjop}	Junction temperature	Continuous operation (under switching)	-40 ~ +150	
T_{stg}	Storage temperature	-	-40 ~ +125	

ELECTRICAL CHARACTERISTICS ($T_{vj}=25\text{ }^{\circ}\text{C}$, unless otherwise specified)

Symbol	Item	Conditions (note10)	Limits			Unit	
			Min.	Typ.	Max.		
I_{DSX}	Drain-source cut-off current	$V_{DS}=V_{DSX}$, $V_{GS}=-15\text{ V}$	-	-	22	mA	
		$V_{DS}=800\text{ V}$, $V_{GS}=-15\text{ V}$	-	-	0.5		
I_{GSS}	Gate-source leakage current	$V_{GS}=V_{GSS}$, D-S short-circuited	-	-	0.5	μA	
$V_{GS(th)}$	Gate-source threshold voltage	$I_D=135\text{ mA}$, $V_{DS}=10\text{ V}$	0.5	1	1.6	V	
$r_{DS(on)}$ (chip)	Static drain-source On-state resistance	$I_D=400\text{ A}$, $V_{GS}=15\text{ V}$ (Note.6)	$T_{vj}=25\text{ }^{\circ}\text{C}$	-	3.2	-	m Ω
			$T_{vj}=150\text{ }^{\circ}\text{C}$	-	5.6	-	
$V_{DS(on)}$ (chip)	Static drain-source On-state voltage	$I_D=400\text{ A}$, $V_{GS}=15\text{ V}$ (Note.6)	$T_{vj}=25\text{ }^{\circ}\text{C}$	-	1.3	-	V
			$T_{vj}=125\text{ }^{\circ}\text{C}$	-	2.02	-	
			$T_{vj}=150\text{ }^{\circ}\text{C}$	-	2.2	-	
$V_{DS(on)}$ (terminal)	Static drain-source On-state voltage	$I_D=400\text{ A}$, $V_{GS}=15\text{ V}$ (Note.6)	$T_{vj}=25\text{ }^{\circ}\text{C}$	-	1.66	2.3	V
			$T_{vj}=125\text{ }^{\circ}\text{C}$	-	2.38	-	
			$T_{vj}=150\text{ }^{\circ}\text{C}$	-	2.56	-	
C_{iss}	Input capacitance	$V_{DS}=10\text{ V}$, $V_{GS}=0\text{ V}$	-	35	-	nF	
C_{oss}	Output capacitance		-	13	-		
C_{rss}	Reverse transfer capacitance		-	1	-		
Q_G	Gate charge	$V_{DD}=600\text{ V}$, $I_D=400\text{ A}$, $V_{GS}=15\text{ V}$	-	1400	-	nC	
$t_{d(on)}$	Turn-on delay time	$V_{DD}=600\text{ V}$, $I_D=400\text{ A}$, $V_{GS}=\pm 15\text{ V}$, $R_G=4.4\Omega$, Inductive load	-	120	-	ns	
t_r	Rise time		-	80	-		
$t_{d(off)}$	Turn-off delay time		-	420	-		
t_f	Fall time		-	60	-		
Q_C	Drain-source charge		-	2	-		μC
V_{SD} (Note.1) (chip)	Source-drain voltage	$I_S=400\text{ A}$ (Note.6) $V_{GS}=-15\text{ V}$	$T_{vj}=25\text{ }^{\circ}\text{C}$	-	1.7	-	V
			$T_{vj}=125\text{ }^{\circ}\text{C}$	-	2.2	-	
			$T_{vj}=150\text{ }^{\circ}\text{C}$	-	2.4	-	
V_{SD} (Note.1) (terminal)	Source-drain voltage	$I_S=400\text{ A}$ (Note.6) $V_{GS}=-15\text{ V}$	$T_{vj}=25\text{ }^{\circ}\text{C}$	-	2.05	2.45	V
			$T_{vj}=125\text{ }^{\circ}\text{C}$	-	2.55	-	
			$T_{vj}=150\text{ }^{\circ}\text{C}$	-	2.75	-	
E_{on}	Turn-on switching energy per pulse	$V_{DD}=600\text{ V}$, $I_D/I_S=400\text{ A}$,	-	11	-	mJ	
E_{off}	Turn-off switching energy per pulse	$V_{GS}=\pm 15\text{ V}$, $R_G=4.4\Omega$, $T_{vj}=125\text{ }^{\circ}\text{C}$,	-	20	-		
E_{rec} (Note.1)	Diode switching energy per pulse	Inductive load	-	0.5	-		
$R_{DD'+SS'}$	Internal lead resistance	P-N, $T_C=25\text{ }^{\circ}\text{C}$ (Note.2)	-	1.0	-	m Ω	
r_g	Internal gate resistance	per Tr1a chips total, per Tr1b chips total, per Tr2a chips total, per Tr2b chips total (internal connection in page 5.)	-	1.1	-	Ω	
L_s	Internal stray inductance	P-N	-	18	-	nH	

Caution; No short-circuit capability is designed.

FMF400BX-24A

HIGH POWER SWITCHING USE

INSULATED TYPE

THERMAL RESISTANCE CHARACTERISTICS

Symbol	Item	Conditions	Limits			Unit
			Min.	Typ.	Max.	
$R_{th(j-c)Q}$	Thermal resistance (Note.2)	Junction to case, per Tr1a chips total, per Tr1b chips total, per Tr2a chips total, per Tr2b chips total, (internal connection in page 5.)	-	-	84	K/kW
$R_{th(j-c)D}$		Junction to case, per Di1a chips total, per Di1b chips total, per Di2a chips total, per Di1b chips total, (internal connection in page 5.)	-	-	122	
$R_{th(c-s)}$	Contact thermal resistance (Note.2)	Case to heat sink, Thermal grease applied (Note.8)	-	15	-	K/kW

NTC THERMISTOR PART

Symbol	Item	Conditions	Limits			Unit
			Min.	Typ.	Max.	
R_{25}	Zero-power resistance	$T_C=25\text{ }^\circ\text{C}$ (Note.2)	4.85	5.00	5.15	k Ω
$\Delta R/R$	Deviation of resistance	$T_C=100\text{ }^\circ\text{C}$, $R_{100}=493\text{ }\Omega$ (Note.2)	-7.3	-	+7.8	%
$B_{(25/50)}$	B-constant	Approximate by equation (Note.7)	-	3375	-	K
P_{25}	Power dissipation	$T_C=25\text{ }^\circ\text{C}$ (Note.2)	-	-	10	mW

FMF400BX-24A

HIGH POWER SWITCHING USE
INSULATED TYPE

MECHANICAL CHARACTERISTICS

Symbol	Item	Conditions	Limits			Unit
			Min.	Typ.	Max.	
M_t	Mounting torque	Main terminals M 6 screw	3.5	4.0	4.5	N·m
M_s		Mounting to heat sink M 5 screw	2.5	3.0	3.5	
d_s	Creepage distance	Terminal to terminal	12	-	-	mm
		Terminal to base plate	13.6	-	-	
d_a	Clearance	Terminal to terminal	10	-	-	mm
		Terminal to base plate	12.3	-	-	
m	mass	-	-	390	-	g
e_c	Flatness of base plate	On the centerline X, Y (Note.5)	± 0	-	+100	μm

*: This product is compliant with the Restriction of the Use of Certain Hazardous Substances in Electrical and Electronic Equipment (RoHS) directive 2011/65/EU.

Note1. Represent ratings and characteristics of the anti-parallel, source-drain free wheeling diode (FWD).

- Case temperature (T_c) and heat sink temperature (T_s) are defined on the each surface (mounting side) of base plate and heat sink just under the chips. Refer to the figure of chip location.
- Pulse width and repetition rate should be such that the device junction temperature (T_{vj}) dose not exceed T_{vjmax} rating.
- Junction temperature (T_{vj}) should not increase beyond T_{vjmax} rating.
- The base plate (mounting side) flatness measurement points (X, Y) are as follows of the following figure.

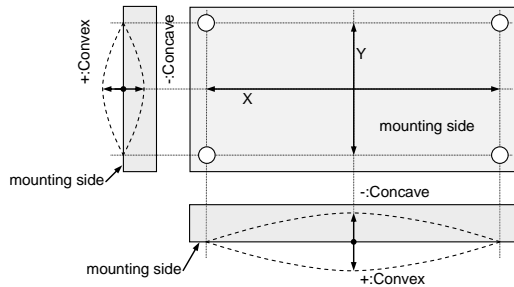

- Pulse width and repetition rate should be such as to cause negligible temperature rise. Refer to the figure of test circuit.

$$7. B_{(25/50)} = \ln\left(\frac{R_{25}}{R_{50}}\right) / \left(\frac{1}{T_{25}} - \frac{1}{T_{50}}\right)$$

R_{25} : resistance at absolute temperature T_{25} [K]; $T_{25}=25\text{ [}^\circ\text{C]}+273.15=298.15$ [K]

R_{50} : resistance at absolute temperature T_{50} [K]; $T_{50}=50\text{ [}^\circ\text{C]}+273.15=323.15$ [K]

- Typical value is measured by using thermally conductive grease of $\lambda=0.9\text{ W/(m}\cdot\text{K)}$.
- Use the following screws when mounting the printed circuit board (PCB) on the standoffs.
"φ2.6×10 or φ2.6×12, B1 tapping screw"
The length of the screw depends on the thickness ($t_{1.6}$) of the PCB.
- Per switch (ex. Tr1 chips total in page.5)

RECOMMENDED OPERATING CONDITIONS

Symbol	Item	Conditions	Limits			Unit
			Min.	Typ.	Max.	
V_{DD}	(DC) Supply voltage	Applied across aP/bP-aN/bN	-	600	850	V
$V_{GS(+)}$	Gate (-source drive) voltage (positive)	Applied across aG1-aS1/bG1-bS1/ aG2-aS2/bG2-bS2	13.5	15	16.5	V
$V_{GS(-)}$	Gate (-source drive) voltage (negative)	Applied across aG1-aS1/bG1-bS1/ aG2-aS2/bG2-bS2	-16.5	-15.0	-9	V
R_G	External gate resistance (Note.11)	Per switch	2.2	-	18	Ω

Note 11. The value of external gate resistance should be considered the surge voltage not to exceed the rating voltage in the worst system condition.

FMF400BX-24A

HIGH POWER SWITCHING USE
INSULATED TYPE

CHIP LOCATION (Top view)

Dimension in mm, tolerance: ±1 mm

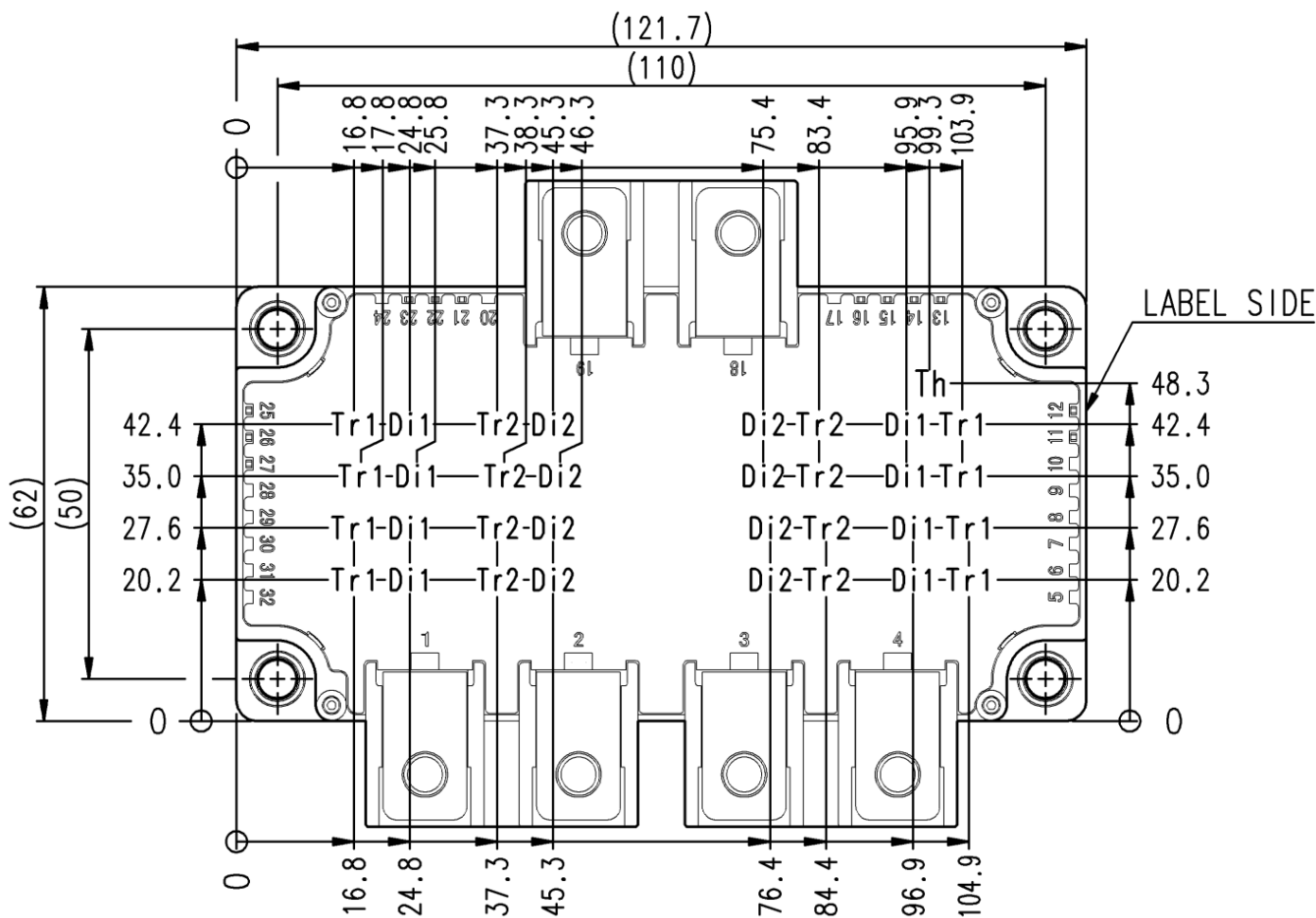

Tr1/Tr2: SiC-MOS, Di1/Di2: SiC-SBD, Th: NTC thermistor

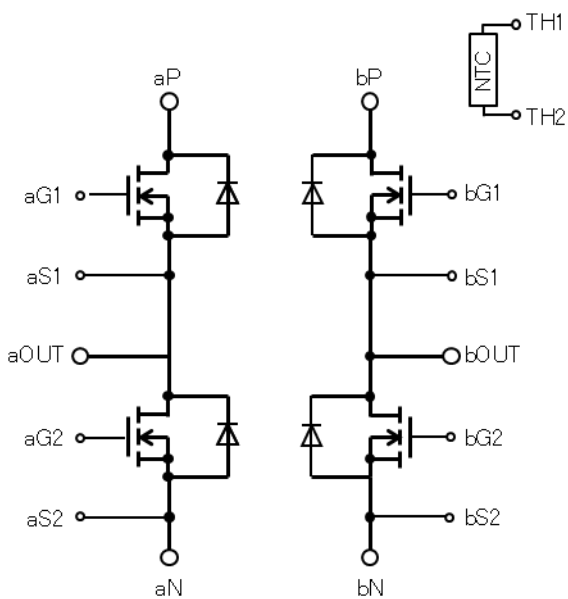

Internal connection

Terminal	code
1	aP
2	aN
3	bN
4	bP
11	bG1
12	bS1
13	TH2
14	TH1
15	bG2
16	bS2
18	bOUT
19	aOUT
21	aS2
22	N.C.
23	aG2
25	aS1
26	N.C.
27	aG1

FMF400BX-24A

HIGH POWER SWITCHING USE
INSULATED TYPE

TEST CIRCUIT AND WAVEFORMS

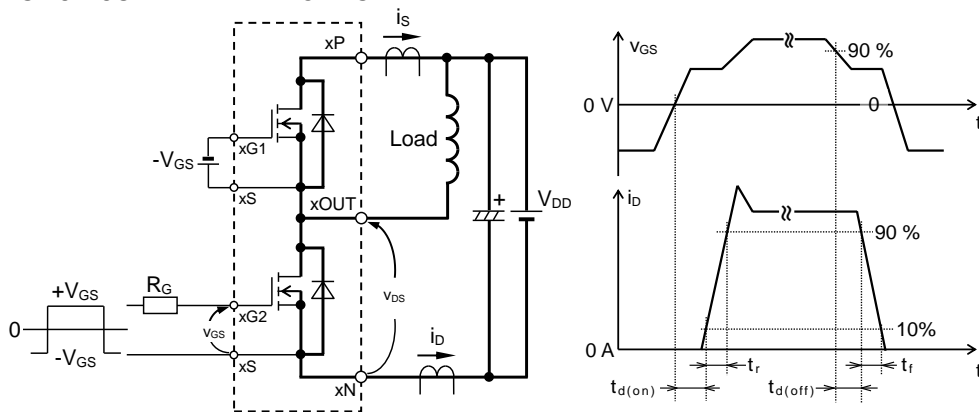

Switching test circuit and waveforms (x: Connected a* or b*)

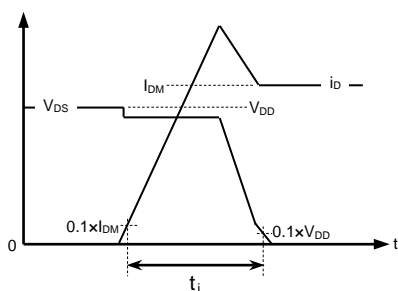

MOSFET Turn-on switching energy

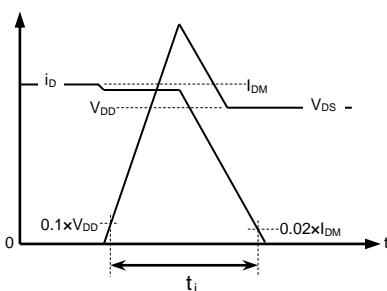

MOSFET Turn-off switching energy

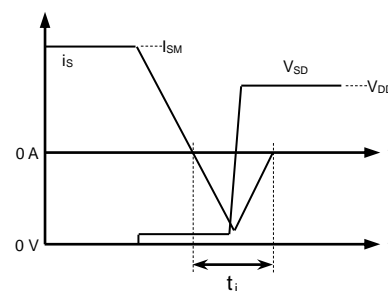

Diode switching energy

Turn-on / Turn-off switching energy and Diode switching energy test waveforms (Integral time instruction drawing)

TEST CIRCUIT

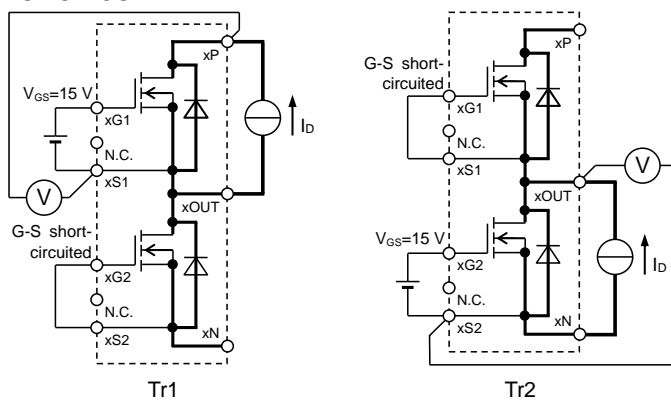

$V_{DS(on)}$ test circuit (x: Connected a* or b*)

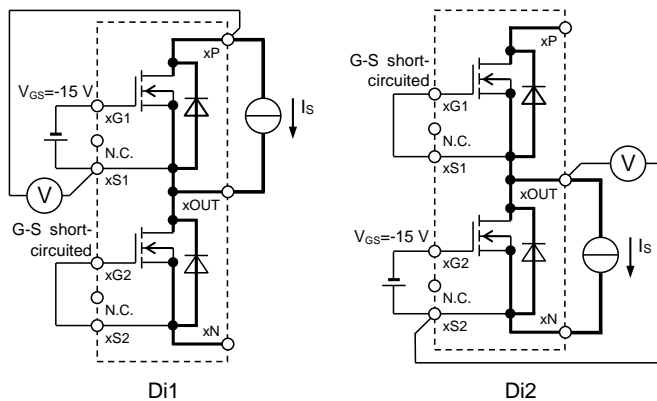

V_{SD} test circuit, $V_{GS}=-15V$ (x: Connected a* or b*)

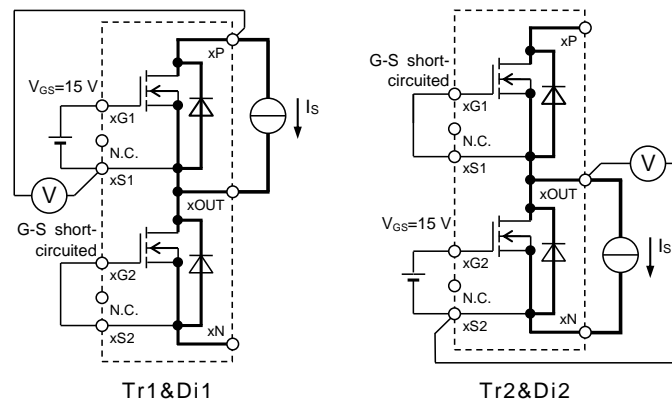

$V_{SD(on)}$ test circuit, $V_{GS}=+15V$ (x: Connected a* or b*)

Note: The characteristics curves are presented for reference only and not guaranteed by production test, unless otherwise noted.

FMF400BX-24A

HIGH POWER SWITCHING USE
INSULATED TYPE

PERFORMANCE CURVES

OUTPUT CHARACTERISTICS (TYPICAL)

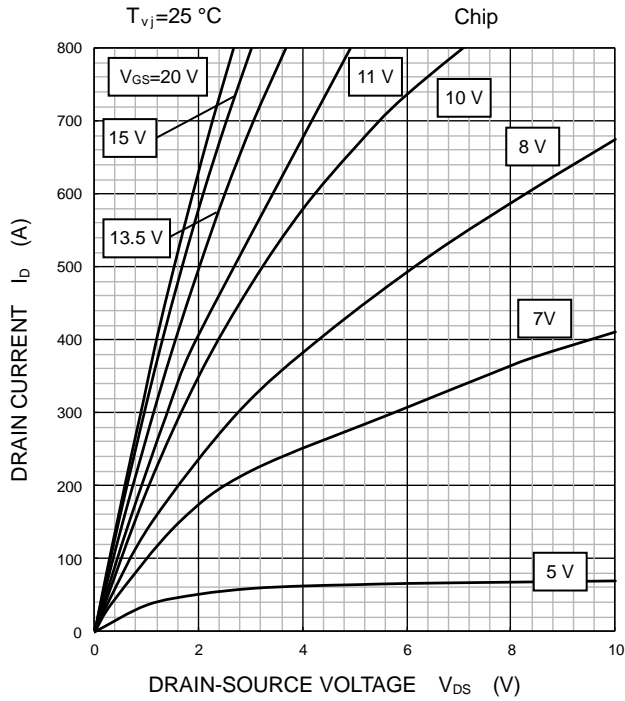

DRAIN-SOURCE ON STATE VOLTAGE CHARACTERISTICS (TYPICAL)

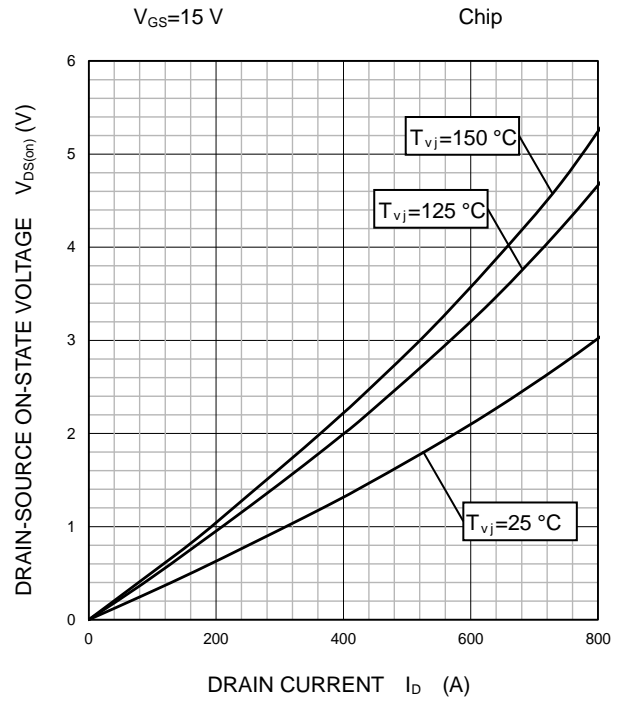

DRAIN-SOURCE ON STATE VOLTAGE CHARACTERISTICS (TYPICAL)

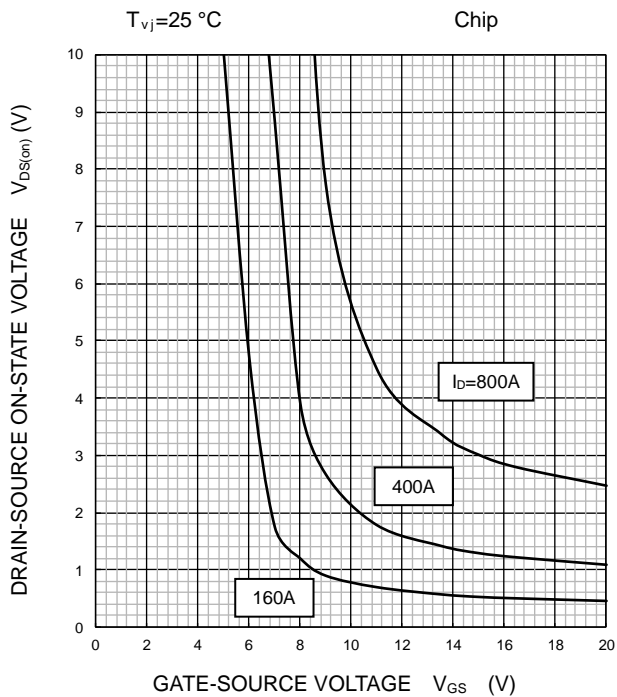

FMF400BX-24A

HIGH POWER SWITCHING USE
INSULATED TYPE

PERFORMANCE CURVES

FREE WHEELING DIODE
FORWARD CHARACTERISTICS
(TYPICAL)

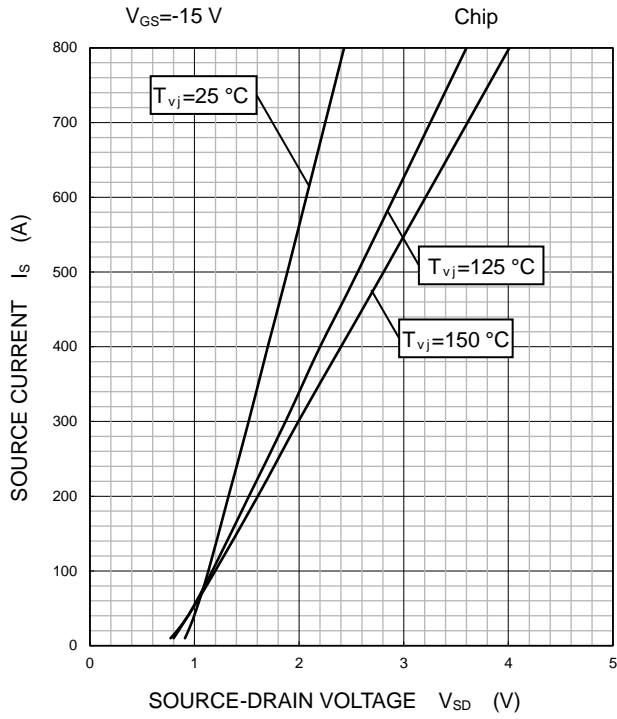

SOURCE-DRAIN ON STATE VOLTAGE
CHARACTERISTICS
(TYPICAL)

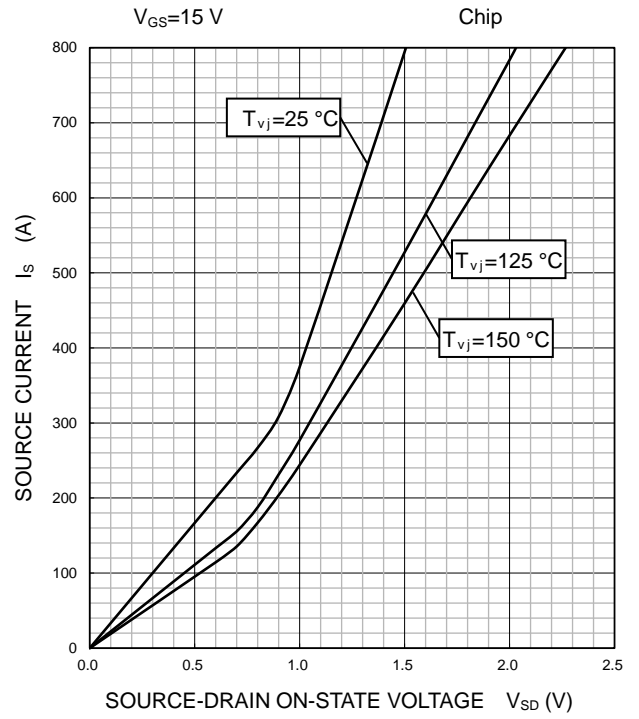

CAPACITANCE
CHARACTERISTICS
(TYPICAL)

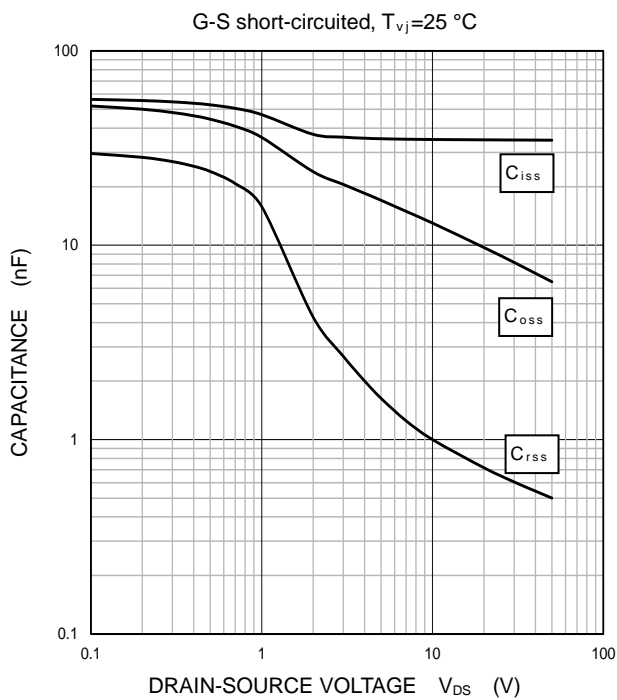

GATE CHARGE
CHARACTERISTICS
(TYPICAL)

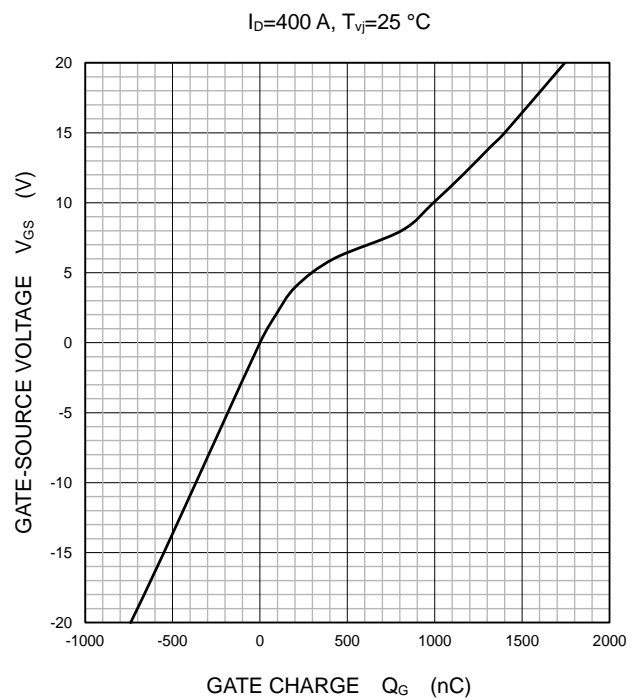

FMF400BX-24A

HIGH POWER SWITCHING USE
INSULATED TYPE

PERFORMANCE CURVES

HALF-BRIDGE
SWITCHING CHARACTERISTICS
(TYPICAL)

$V_{DD}=600\text{ V}$, $V_{GS}=\pm 15\text{ V}$, $R_G=4.4\Omega$,
 $T_{vj}=125\text{ }^\circ\text{C}$, INDUCTIVE LOAD

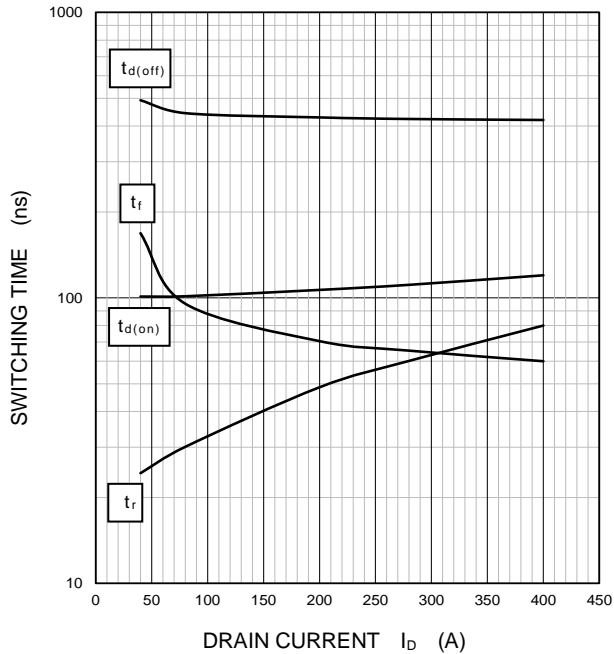

HALF-BRIDGE
SWITCHING CHARACTERISTICS
(TYPICAL)

$V_{DD}=600\text{ V}$, $V_{GS}=\pm 15\text{ V}$, $I_D=400\text{ A}$,
 $T_{vj}=125\text{ }^\circ\text{C}$, INDUCTIVE LOAD

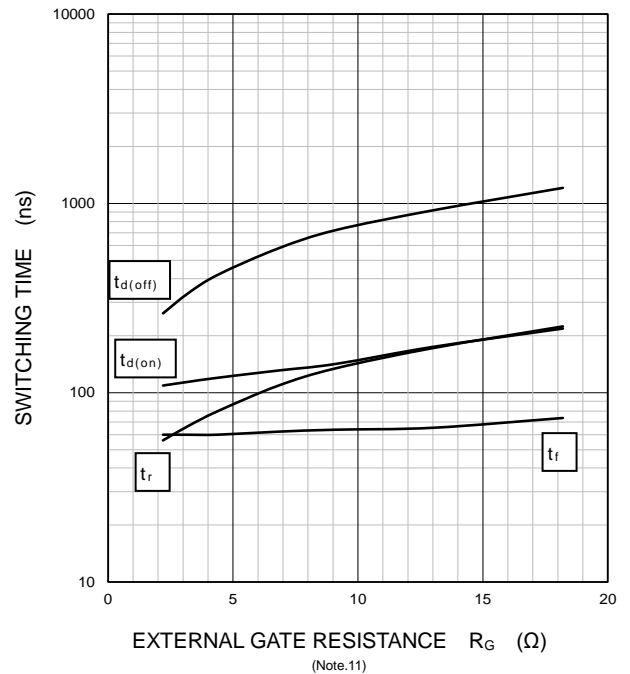

HALF-BRIDGE
SWITCHING CHARACTERISTICS
(TYPICAL)

$V_{DD}=600\text{ V}$, $V_{GS}=\pm 15\text{ V}$, $R_G=4.4\Omega$, $T_{vj}=125\text{ }^\circ\text{C}$,
INDUCTIVE LOAD, PER PULSE

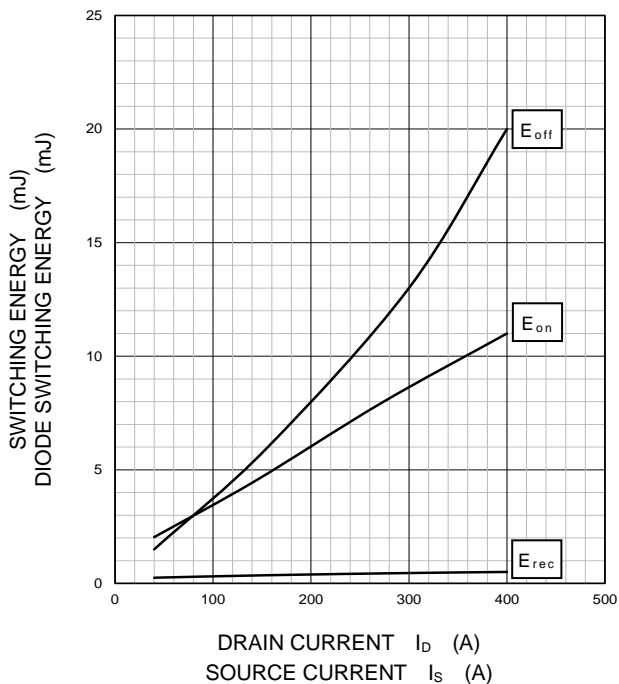

HALF-BRIDGE
SWITCHING CHARACTERISTICS
(TYPICAL)

$V_{DD}=600\text{ V}$, $V_{GS}=\pm 15\text{ V}$, $I_D/I_S=400\text{ A}$, $T_{vj}=125\text{ }^\circ\text{C}$,
INDUCTIVE LOAD, PER PULSE

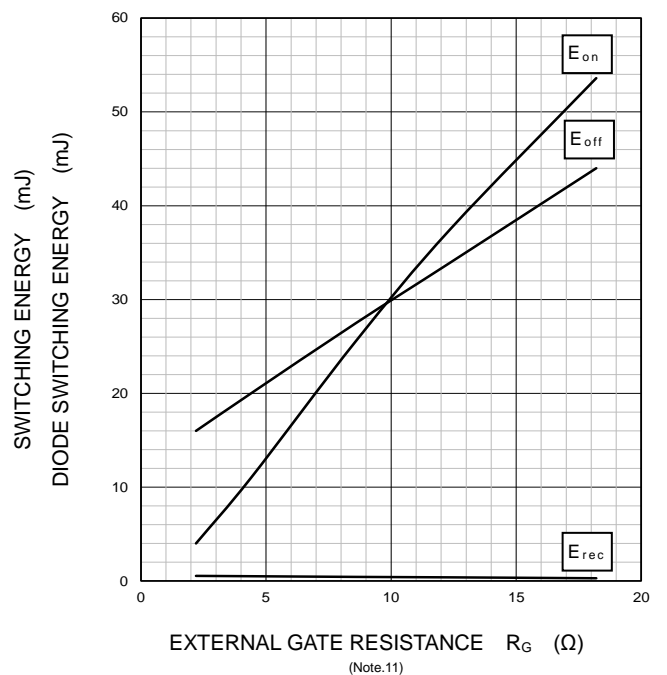

FMF400BX-24A

HIGH POWER SWITCHING USE
INSULATED TYPE

PERFORMANCE CURVES

RECOMMENDED GATE RESISTANCE
(MINIMUM)

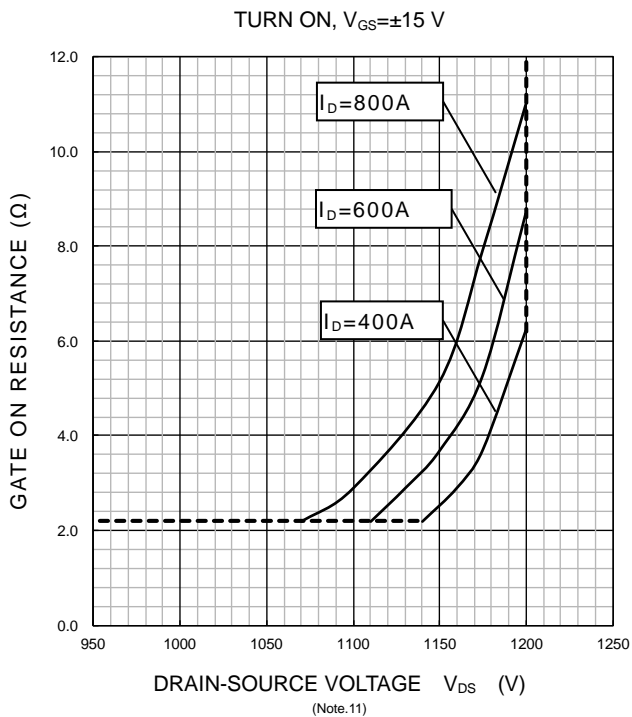

RECOMMENDED GATE RESISTANCE
(MINIMUM)

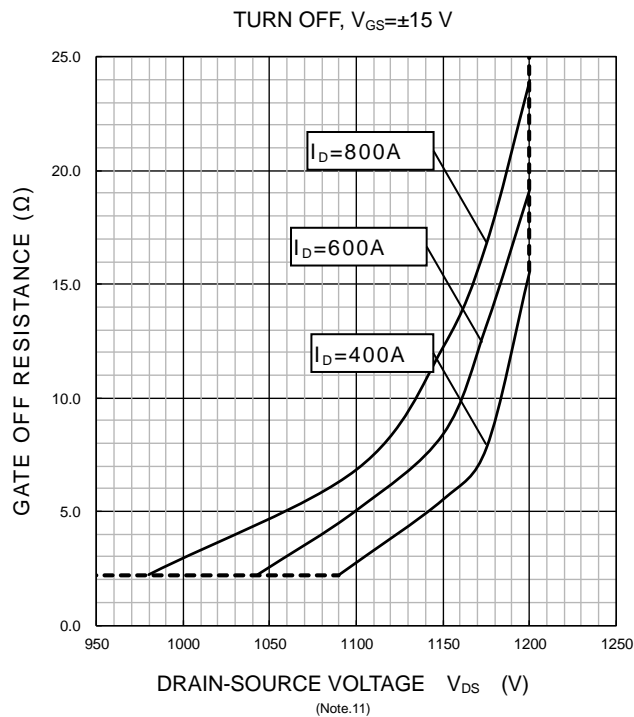

TRANSIENT THERMAL IMPEDANCE
CHARACTERISTICS
(MAXIMUM)

Single pulse, $T_C = 25\text{ }^\circ\text{C}$
 $R_{th(j-c)Q} = 0.84\text{ K/W}$, $R_{th(j-c)D} = 1.22\text{ K/W}$

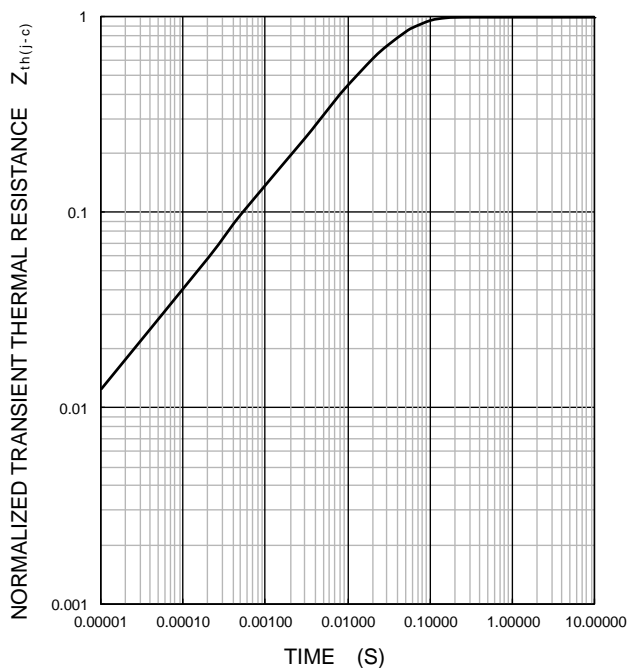

NTC thermistor part

TEMPERATURE
CHARACTERISTICS
(TYPICAL)

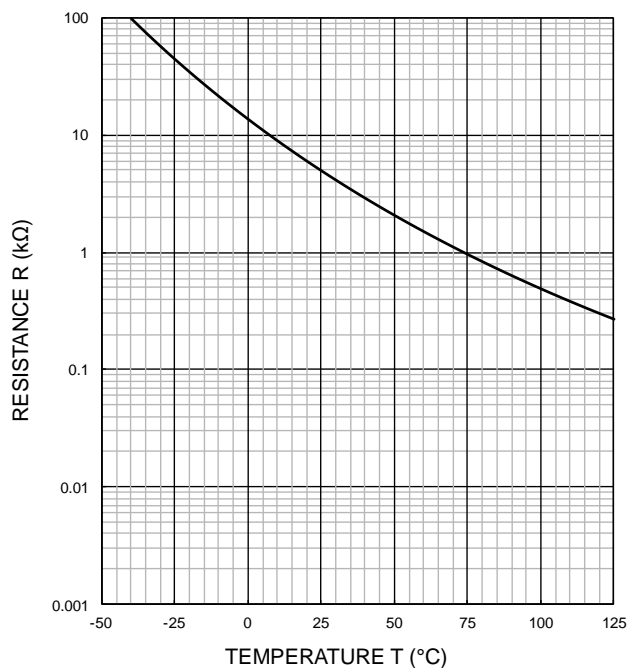

Note: The characteristics curves are presented for reference only and not guaranteed by production test, unless otherwise noted.

FMF400BX-24A

HIGH POWER SWITCHING USE
INSULATED TYPE

Keep safety first in your circuit designs!

This product is designed for industrial application purpose. The performance, the quality and support level of the product is guaranteed by "Customer's Std. Spec."

Mitsubishi Electric Corporation puts its reasonable effort into making semiconductor products better and more reliable, but there is always the possibility that trouble may occur with them by the reliability lifetime such as Power Cycle, Thermal Cycle or others, or to be used under special circumstances (e.g. high humidity, dusty, salty, highlands, environment with lots of organic matter / corrosive gas / explosive gas, or situation which terminal of semiconductor products is received strong mechanical stress).

In the customer's research and development, please evaluate it not only with a single semiconductor product but also in the entire system, and judge whether it's applicable. Furthermore, trouble with semiconductors may lead to personal injury, fire or property damage. Remember to give due consideration to safety when making your circuit designs, with appropriate measures such as (i) placement of substitutive, auxiliary circuits (e.g. appropriate fuse or circuit breaker between a power supply and semiconductor products), (ii) use of non-flammable material or (iii) prevention against any malfunction or mishap.

Notes regarding these materials

- These materials are intended as a reference to assist our customers in the selection of the Mitsubishi semiconductor product best suited to the customer's application; they do not convey any license under any intellectual property rights, or any other rights, belonging to Mitsubishi Electric Corporation or a third party.
- Mitsubishi Electric Corporation assumes no responsibility for any damage, or infringement of any third-party's rights, originating in the use of any product data, diagrams, charts, or circuit application examples contained in these materials.
- All information contained in these materials, including product data, diagrams and charts represents information on products at the time of publication of these materials, and are subject to change by Mitsubishi Electric Corporation without notice due to product improvements or other reasons. It is therefore recommended that customers contact Mitsubishi Electric Corporation or an authorized Mitsubishi Semiconductor product distributor for the latest product information before purchasing a product listed herein.
The information described here may contain technical inaccuracies or typographical errors. Mitsubishi Electric Corporation assumes no responsibility for any damage, liability, or other loss rising from these inaccuracies or errors.
Please also pay attention to information published by Mitsubishi Electric Corporation by various means, including the Mitsubishi Semiconductor home page (www.MitsubishiElectric.com/semiconductors/).
- When using any or all of the information contained in these materials, including product data, diagrams, and charts, please be sure to evaluate all information as a total system before making a final decision on the applicability of the information and products. Mitsubishi Electric Corporation assumes no responsibility for any damage, liability or other loss resulting from the information contained herein.
- Mitsubishi Electric Corporation semiconductors are not designed or manufactured for use in a device or system that is used under circumstances in which human life is potentially at stake. Therefore, this product should not be used in such applications.
Please contact Mitsubishi Electric Corporation or an authorized Mitsubishi Semiconductor product distributor when considering the use of a product contained herein for any specific purposes, such as apparatus or systems for transportation, vehicular, medical, aerospace, nuclear, or undersea repeater use.
- In the case of new requirement is available, this material will be revised upon consultation.
- The prior written approval of Mitsubishi Electric Corporation is necessary to reprint or reproduce in whole or in part these materials.
- If these products or technologies are subject to the Japanese export control restrictions, they must be exported under a license from the Japanese government and cannot be imported into a country other than the approved destination.
Any diversion or re-export contrary to the export control laws and regulations of Japan and/or the country of destination is prohibited.
- Please contact Mitsubishi Electric Corporation or an authorized Mitsubishi Semiconductor product distributor for further details on these materials or the products contained therein.

Generally the listed company name and the brand name are the trademarks or registered trademarks of the respective companies.